

## STAINLESS STEEL ACCESSORIES

# KENWORTH T800, 1995+ 13" BOWTIE SUNVISOR, OEM REPLACEMENT

### INSTALLATION INSTRUCTIONS

1. DO NOT REMOVE entire plastic coating until the last step. Peel plastic from hems and at center flange
2. Remove OEM stainless steel sunvisor. OEM brackets must be removed by drilling out rivets. Keep OEM end bolts for re-use.
3. Remove upper console from inside cab.
4. The original rivet holes in roof can be opened up using 9/32 drill bit.
5. Using 1/4-20 x 5/8" hardware supplied assemble the slide bracket onto the cab bracket. Snug up hardware leaving loose enough for further adjustment.

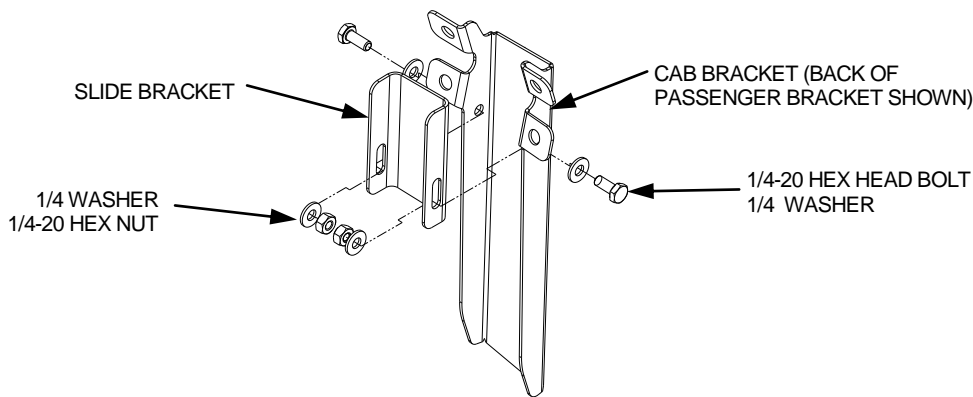

6. If the outer brackets of the existing visor are fastened with only two bolts it will be necessary to use the supplied adaptor plate. Remove the brackets and fasten adaptor plate through existing rivet holes. Mark and drill the 4 holes using a 9/32 drill bit. Proceed to Step #8.

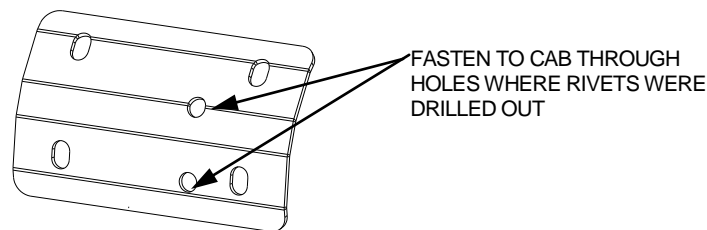

## STAINLESS STEEL ACCESSORIES

7. If your truck does not have the center bracket holes, these will need to be marked and drilled. Proceed to Step#8.
8. Loosely fit cab brackets to cab. This step is just to mark the holes that need to be drilled and the brackets will need to be removed prior to final installation and the application of silicon.
9. Install visor halves securing with the end bolt first. Slide visor onto bottom of locking bracket ensuring that the bracket is seated in the notches in the bottom hem. Push slide bracket into the notches in the top of the visor.

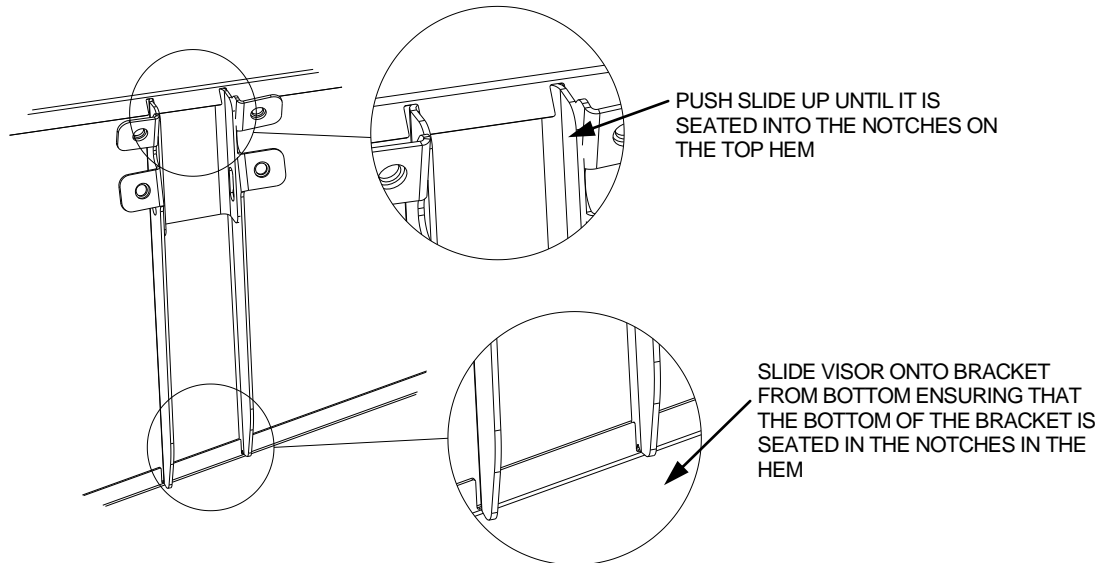

10. Loosely install center brackets to the visor ensuring that the visor flanges are sandwiched between the brackets. Ensure the sliding/locking brackets are still properly locked in the notches. Mark the hole locations for the centre brackets and the second end bolts on each end of the visor.
11. Remove the visor halves and drill holes for end bolts using 25/64 drill bit. Install the supplied nutserts following the enclosed instructions.
12. Drill holes for the centre bracket marked in Step #10 using a 9/32 drill bit.
13. Remove all brackets and apply a generous amount of silicon to and around all holes.
14. Reinstall brackets and backing plates inside cab. Leave hardware loose enough for adjustment.
15. Apply two or three 3/4" dollops of silicon to the surface of the outer brackets (helps in prevention of vibration) and into the end bolt hole locations.

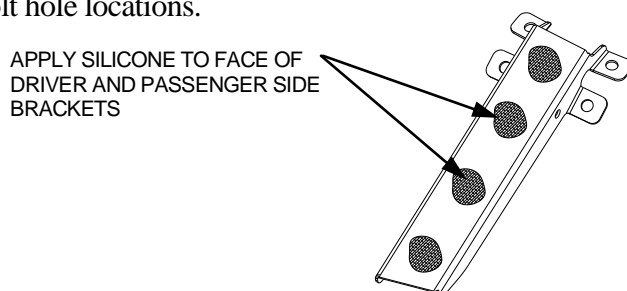

## **STAINLESS STEEL ACCESSORIES**

- 16. Leave all hardware loose enough for adjustment until final install.**
17. Install visor halves securing with the end bolt first. Slide visor onto bottom of locking bracket ensuring that the bracket is seated in the notches in the bottom hem. Make sure that the flanges are pinched between the centre brackets and push slide bracket into the notches in the top of the visor.
18. Using the 1/4-20 x 3/4, loosely fasten the centre brackets together ensuring that the visor flanges are sandwiched in between.
19. Ensuring that the visors are still securely locked in place at the sliding bracket, tighten the two visor halves together at the center brackets.
20. Tighten slide locking brackets ensuring that bottom and top of bracket are securely locked into the notches in the visor.
21. Tighten all bracket hardware across cab, tightening the end bolts last.
22. Remove remaining plastic film. If necessary, clean visor with glass cleaner and a soft cloth.