

STAINLESS STEEL ACCESSORIES

SKIRT KIT FOR FREIGHTLINER NEW CASCADIA

INSTALLATION INSTRUCTIONS

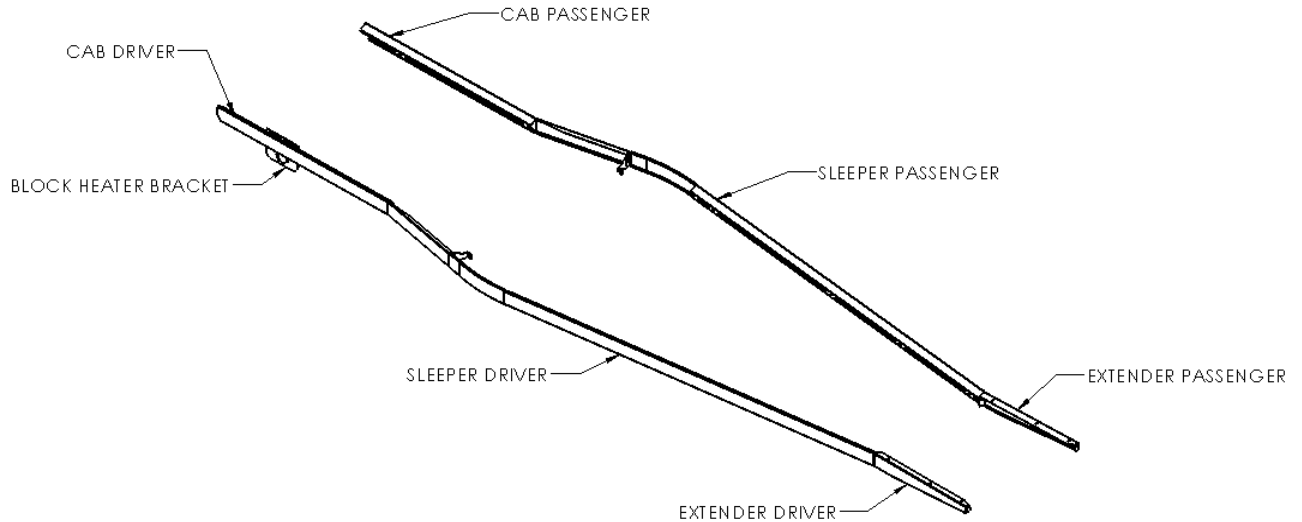

FIGURE 1 – ASSEMBLY

1. Remove factory fiberglass panels.
2. Prepare block heater bracket, where applicable
 - a) For trucks with side fairings using a 2" skirt kit, the factory block heater bracket will need to be removed and replaced with the included Block Heater Bracket. Drill or grind rivets to remove.
TIP: In most cases, a center punch may be used to drive the rivet-center out.
 - b) For trucks without side fairings, using a 2" or 3" skirt kit, the factory block heater bracket can simply be angled back with some force, to make room for the Cab panel.
 - c) For trucks not equipped with block heater, the steps regarding the block heater bracket can be ignored.
3. Temporarily fasten Cab panel to truck using the supplied 1/4"-20 X 3/4" hex head bolts through the existing (2) holes in truck (See Figure 2). Ensure the top of the skirt is snug up against the truck to minimize the gap.
4. Mark rear-most Cab panel hole to be drilled (See Figure 2).
5. Remove Cab panel and drill hole (marked in step 4) to 9/32" diameter.
6. Reinstall Cab panel and fasten in place with supplied hardware. At the same time, fasten the replacement Block Heater Bracket in place of the original bracket. (use 1/4"-20X 3/4" hex head bolts in existing truck holes (x2) as were temporarily installed in step 3, use a 1/4"-20X 1" hex head bolt in the (1) rear-most Cab panel hole that was drilled in step 5, and use 1/4"-20X 1" hex head bolts (x2) in Block Heater Bracket holes. Use (2) flat washers and a locknut at each fastener. (See Figure 2))

STAINLESS STEEL ACCESSORIES

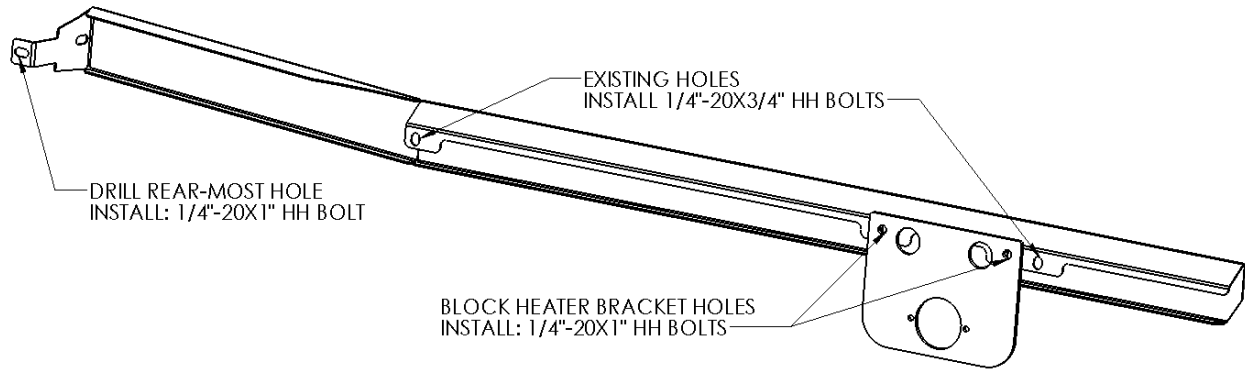

FIGURE 2 – DRIVER CAB PANEL, SHOWN FROM BACK

7. Temporarily fasten the sleeper skirt through four existing holes in truck (See Figure 3). Ensure the top of the skirt is snug up against the truck to minimize the gap.

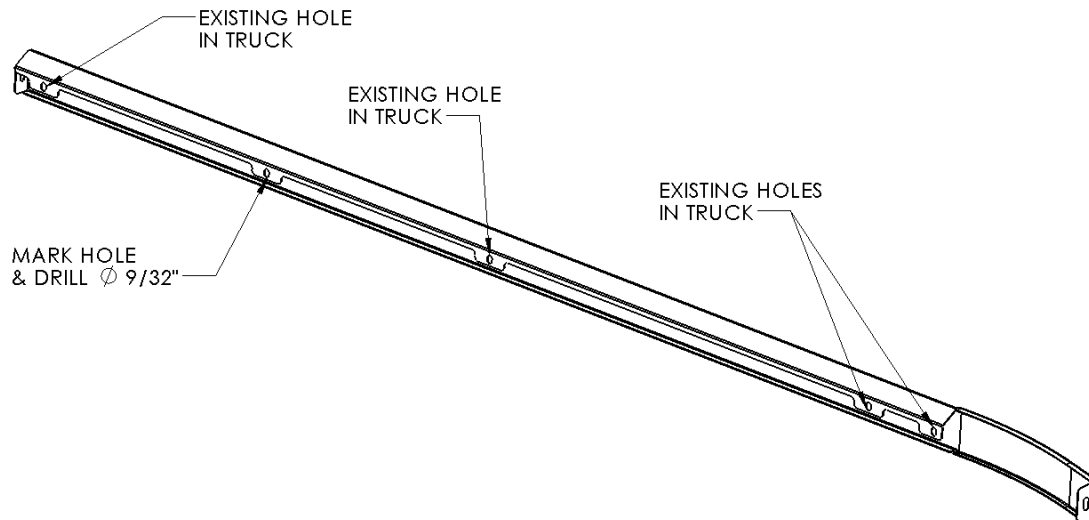

FIGURE 3 – DRIVER SLEEPER PANEL, SHOWN FROM BACK

8. Remove Sleeper panel and drill hole (marked in step 7) to 9/32" diameter.
9. Reinstall Sleeper panel and fasten in place with supplied hardware. Use (5) 1/4"-20X 3/4" hex head bolts with (2) flat washers a (1) locknut at each fastener.
10. Align sleeper panel to Cab panel, and secure together with supplied 1/4"-20X 3/4" hex head bolts with (2) flat washers and a (1) locknut on each fastener.
11. Position Extender panels in place and mark holes to be drilled in bottom of extender.
12. Remove Extender panel and drill holes (marked in step 11) to 7/32" diameter.
13. Reinstall Extender panels and secure with 10-32X3/4" bolts.
14. Repeat all steps on the other side of vehicle.
15. Peel plastic and clean with glass cleaner as required.