

## SKIRT KIT INTERNATIONAL LT

### INSTALLATION INSTRUCTIONS

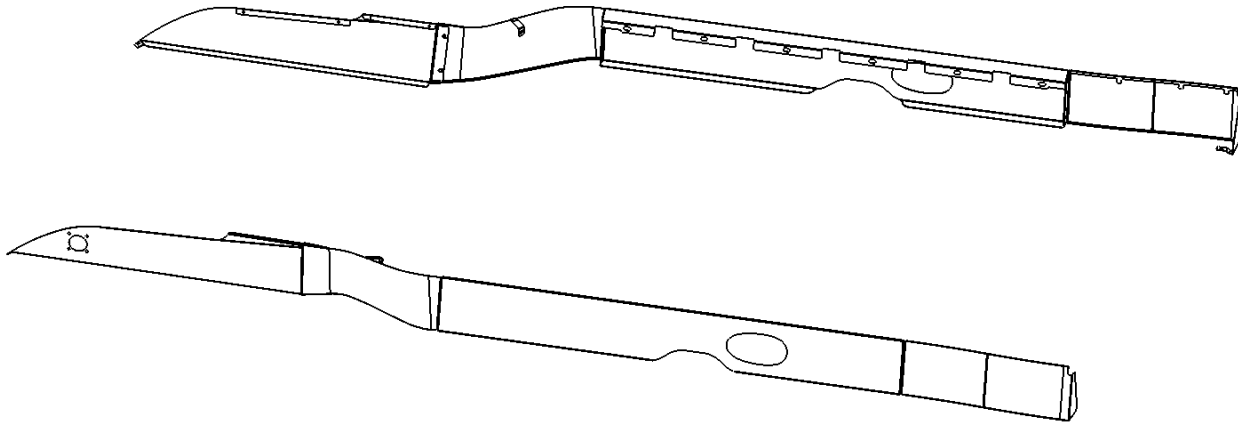

1. Remove factory Sleeper and Transition Panels from both sides of vehicle with 10mm socket.
2. Prepare all panels by scoring the edges and peeling all plastic except from the main faces
3. Mount Sleeper Panels using (12) provided 5/16-18 hex bolts with (24) flat washers & (12) lock nuts.
4. Mark drill holes for Cab skirts using provided template
  - a. Remove marker light and block heater
  - b. Cutout template, including holes. Cut and bend tab as indicated on template (for passenger side).
  - c. Align template
    - i. Align marker light holes (and block heater holes on the driver side)
    - ii. Align top edge of template to top edge of original plastic Cab skirt (with consistent offset)
    - iii. Align back edge of paper template to edge of original plastic Cab skirt
  - d. Mark (2) 1/4" holes for both driver & passenger sides, as well as the (3<sup>rd</sup>) lower hole for the passenger side.
5. Drill holes marked in step 4
6. Position Cab Skirts in place
7. Temporarily unmount rear portion of the *factory* Cab Skirts to provide access behind (see figures 1-4).
  - a. Remove the two T27 screws from rear portion of each Cab Skirt (access through the opening where Transition Panel has been removed from). Retain screws for reassembly.



Figure 1

- b. Flex the molded Cab Skirt bracket towards front of truck to disengage it from locking tab on truck bracket.

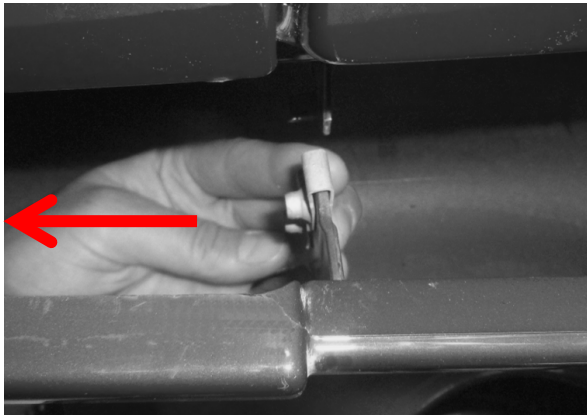

Figure 2

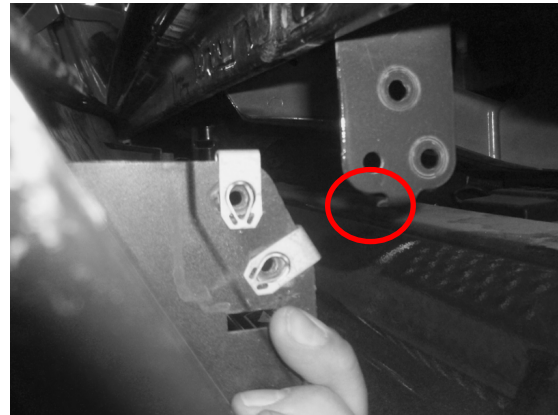

Figure 3

- c. Pull Cab skirt outward to unhook the spring clips located at mid length of Cab Skirt



Figure 4

- 8. Mark and drill the remaining 3 screw holes in Cab Panels
  - a. Mark the lower front Cab Skirt mounting hole, and drill 1/4" hole.
  - b. Drill holes for the remaining 2 screws at the top edge of each Cab Panel.

9. Secure Cab Panels to truck

- a. Install 10-32 washers and locknuts onto the mounting studs (max tightening torque = 23in-lb)
- b. Insert (3) 10-32 bolts into drilled holes, and secure with (3) flat washer and (3) locknuts

10. Drill 9/32" holes through slots in rear of Cab Panels for Transition Panel studs

11. Attach Transition Panel (see figure 5)

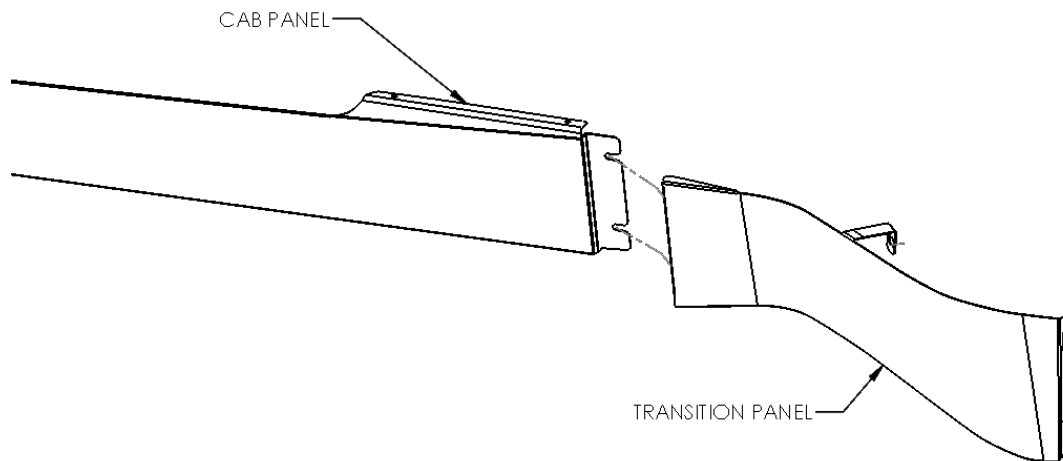

Figure 5

- a. Insert Transition Panel studs through holes.
- b. Install (2) flat washers and (2) locknuts onto studs to secure Transition to Cab Panel. (max tightening torque = 75in-lb)
- c. Secure Transition Panel to truck body using 1/4" hex bolt with fender washer through the middle mounting hole, and install 1/4" flat washer and locknut.
- d. Fasten Transition Panel to Sleeper using (2) 1/4" hex bolts with flat washers and (2) locknuts.

12. Re-mount *factory* Cab Panels

- a. Repeat step 7 in reverse order for reassembly

13. Mark Extender Panel stud holes using provided template

- a. Place paper template onto truck and align with Sleeper Panel



Phone: 519 -884-8555  
Toll Free: 1-877-884-8555



Figure 6

- b. Mark 3 holes. Repeat for other side of truck

#### 14. Install Extender Panels

- a. Place panel into drilled holes.
- b. Mark and drill the lower rear mounting hole
- c. Assemble (2)  $\frac{1}{4}$ -20x5/8 carriage bolts with (4) flat washers and (2) locknuts to Sleeper Panel.
- d. Install (3) flat washers and (3) locknuts onto the 3 studs (max tightening torque = 23in-lb)
- e. Insert (1) 10-32 screw through lower rear mounting hole and secure with (1) flat washer and (1) locknut.

15. Peel all remaining plastic, and clean with glass cleaner as necessary.