

## STAINLESS STEEL ACCESSORIES

### BUSINESS CLASS SUNVISOR Standard and Raised Roof

#### INSTALLATION INSTRUCTIONS

1. It is not necessary to remove headliner for Sunvisor installation.
2. Mark holes of each bracket, equally spaced above windshield onto cab, as shown below.

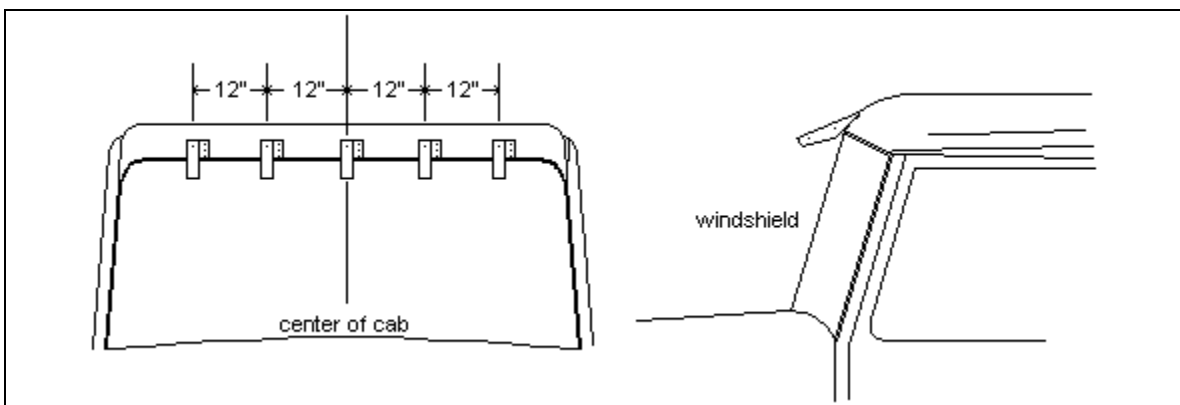

3. Drill holes with 1/8" or #30 bit. Cover the underside of brackets with putty or silicone caulking. Tighten brackets with metal screws supplied.
4. Place Sunvisor on brackets and pull tight on both ends over the eaves trough. Center of Sunvisor has to be centered to the cab. The bottom edge of both ends will have to be parallel to the eaves trough. Drill 1/8" holes into cab through holes in Sunvisor, use putty or silicone again and tighten.

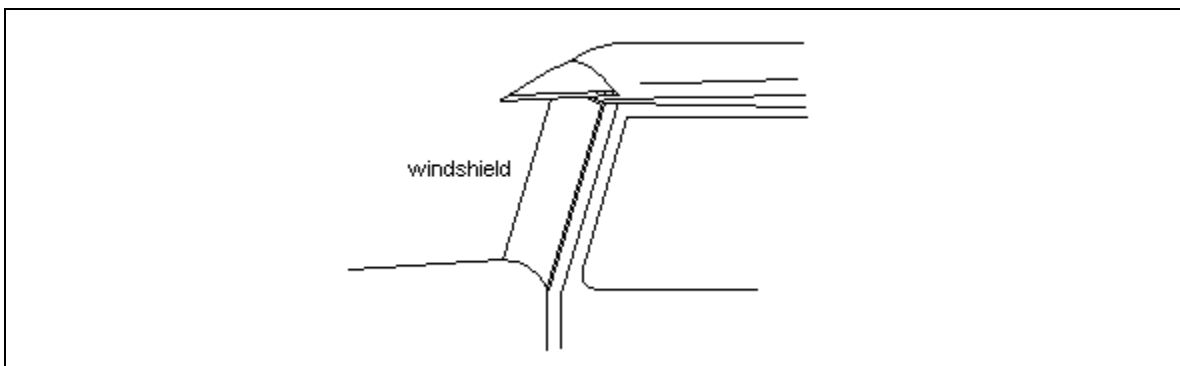

5. Adjust brackets until Sunvisor follows the shape of cab.
6. Drill 3 – 3/16" holes equally spaced through Sunvisor into each bracket. Use 10-32 screws and locknuts supplied, and tighten.
7. Make final adjustments if necessary and remove remaining plastic coating.

