

## CAB PANELS VOLVO VNX300 DAYCAB

### INSTALLATION INSTRUCTIONS

1. Prepare truck for mounting panels.
  - a. On Driver sider, remove OE Block Heater & BH-Bracket. Retain hardware.
  - b. On Passenger side, remove OE marker light. Retain hardware.
2. Position Cab Panel in place and mark holes with a scribe or marker.
3. Drill mounting holes with a 9/32" drill bit.
  - a. Tip: For the rearmost hole, use a 90 degree drill or approach hole from backside.
4. Prepare panels
  - a. Score plastic film at edges and remove all plastic except for from main face of panel.
  - b. Install Passenger marker light onto Passenger Panel, using OE hardware.
  - c. Install Block Heater onto Driver Panel, using OE hardware.
5. Peel plastic from brackets and mount brackets to panels
  - a. Use supplied 10-32 bolts with flat washers and locknuts (see Figure 1)

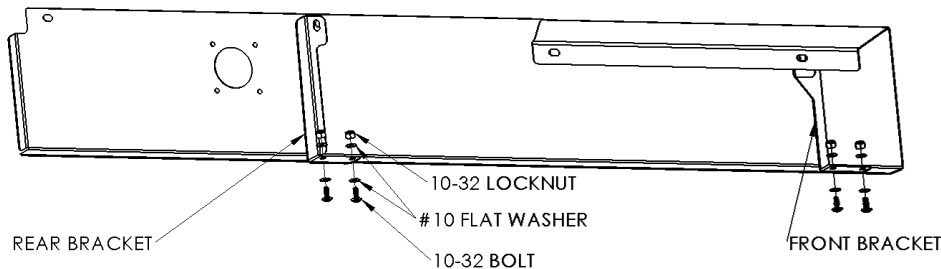

**Figure 1 – Bracket Pre-assembly  
(Driver side shown from inside)**

6. Position Panels in place and mount with supplied 1/4-20 hex head fasteners, using flat washers and locknuts.
  - a. At rear bracket, place a stack of (3) washers (included) between bracket and truck.

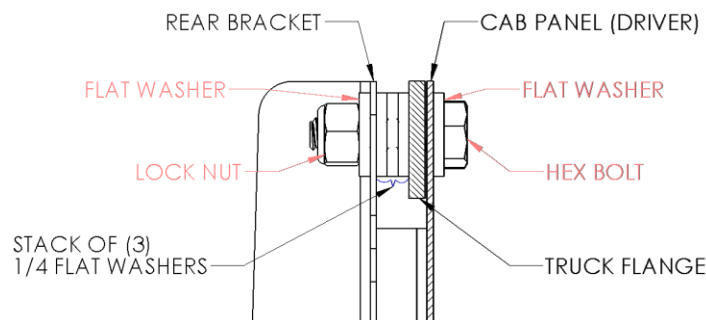

**Figure 2 – Rear Bracket to Truck  
(Driver side shown from front)**

7. Peel all remaining plastic, and clean with glass cleaner as necessary