

## STAINLESS STEEL ACCESSORIES

### KENWORTH T680, 52" SKIRT ASSEMBLY INSTRUCTIONS

#### INSTALLATION INSTRUCTIONS

1. Remove all existing factory installed skirting from the truck. The hardware will be reused for the replacement skirts.
2. On the flange that held the factory transition panels, place the supplied "u-nut" over the flange at the front hole, as shown below. The threaded protrusion faces upwards.
3. Peel the protective plastic from all mounting flanges.
4. Attach the cab and sleeper panels to the truck, picking up on all the existing mounting holes and using the hardware removed from the truck in step 1.
5. Attach the transition panel to the "u-nut" using hardware removed from the truck in step 1. Then attach the transition to the cab and sleeper panels using the supplied 10-32 screws, washers and nuts.
6. Peel remaining plastic from the panels and clean with glass cleaner, if necessary.

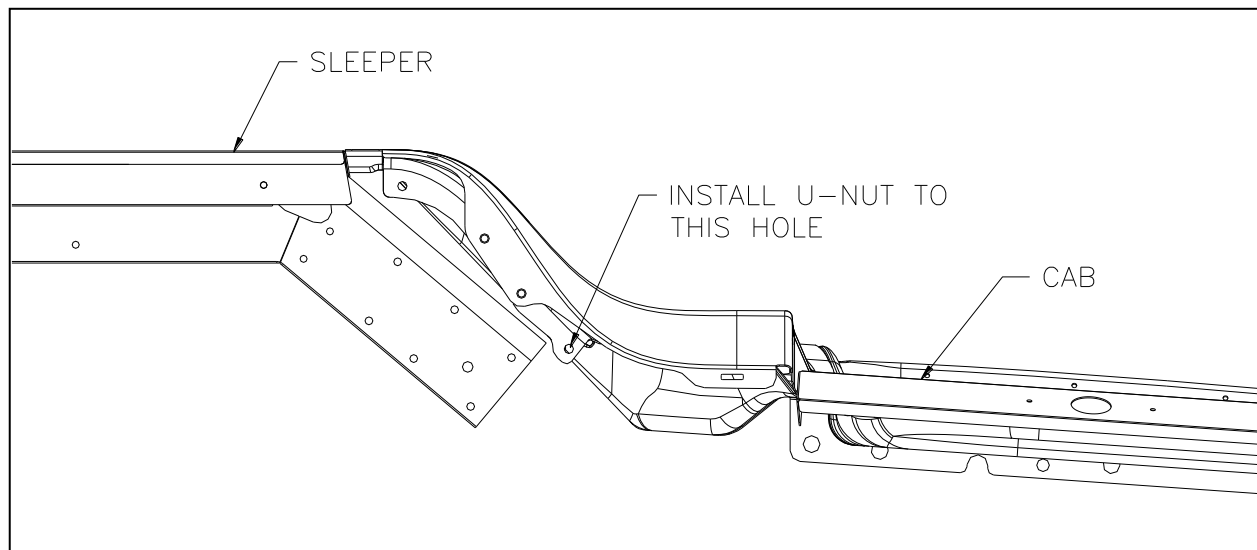

VIEW FROM THE UNDERSIDE OF THE TRUCK ON THE DRIVER'S SIDE