

STAINLESS STEEL ACCESSORIES

TOOLBOX COVER KIT, PASSENGER SIDE, 388/389, 2010+

INSTALLATION INSTRUCTIONS

1. Open truck hood for easier access to the factory toolbox cover bolts.
2. Remove all bolts from the toolbox covers. Set aside for reuse.
3. Remove factory panels. Before removing the lower panel, mark the top flange.
4. It may be required to remove exhaust elbow cover for Peterbilt 388, 2011+ model.
5. Match the geometry of the lower factory panel with the stainless cover. (The small triangular cutout on the flange of the stainless steel cover represents the top of the part.)

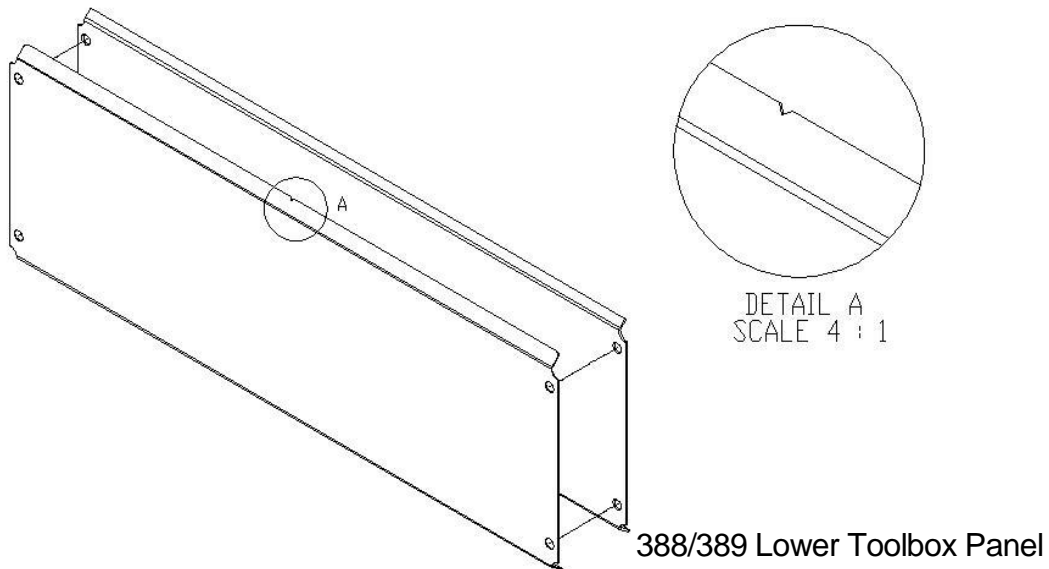

6. Apply a generous amount of silicone to the factory panel.
7. Press factory panel and cover together, ensuring all holes are aligned.
8. Remove the upper panel and discard. The stainless panel will replace the factory panel.
9. Peel plastic coating around mounting holes of the stainless covers.
10. Mount the panels onto the truck starting with the lower panel then the upper panel. Secure panels by threading factory bolts a few turns back into their corresponding holes, if necessary.
11. (It is recommended that Blue Locktite is applied to all bolts, securing the toolbox.) Note: not supplied.
12. Important: do not over tighten bolts. Stainless covers will sink in, dimpling the parts.
13. Remove plastic coating from toolbox panels. Polish with glass cleaner and soft cloth if necessary.