

Stainless Steel Accessories

LOWER HOOD PANEL 389

INSTALLATION INSTRUCTIONS

1. Using 2" masking tape, cover the offset bend in the lower hood as shown.

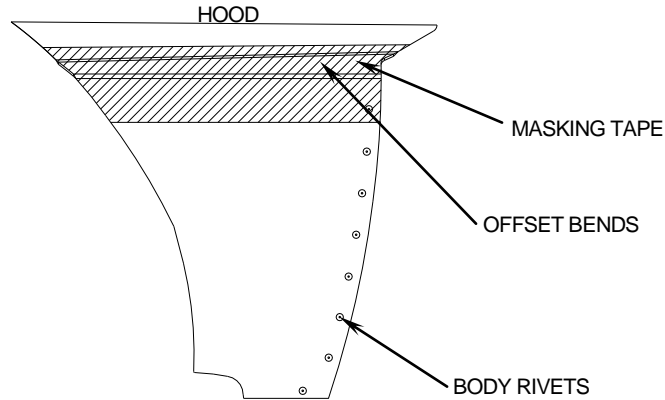

2. Remove plastic coating from hem of panel and from around the bolt holes. Place stainless steel hood panel on the hood and mark a horizontal line along the top edge of the panel onto masking tape.

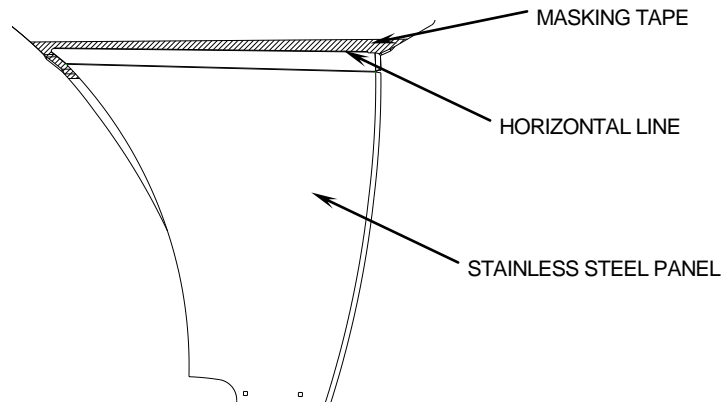

3. Remove panel and place bracket over the offset bend of hood, 1/16" below the horizontal line on the masking tape. Mark and drill 6, #11 holes into the hood. Remove masking tape and fasten the bracket using the pop rivets supplied.

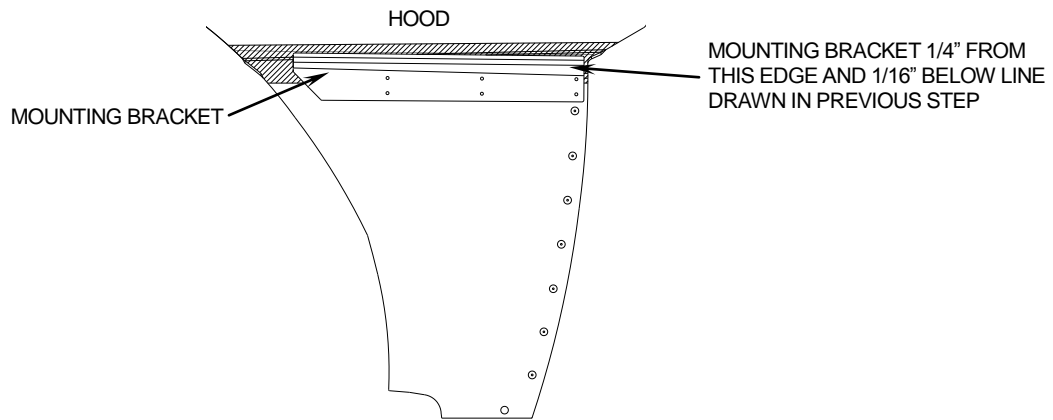

4. Dab silicone over each body rivet and randomly over the lower hood where panel will be installed. (re: potential rattles)
5. Open hood all the way and carefully slide the new panel from the top, down over the bracket. Ensure that the hook at the top of the panel catches on the top edge of the bracket.
6. It is recommended to use a little grease to ease the sliding of the panel.

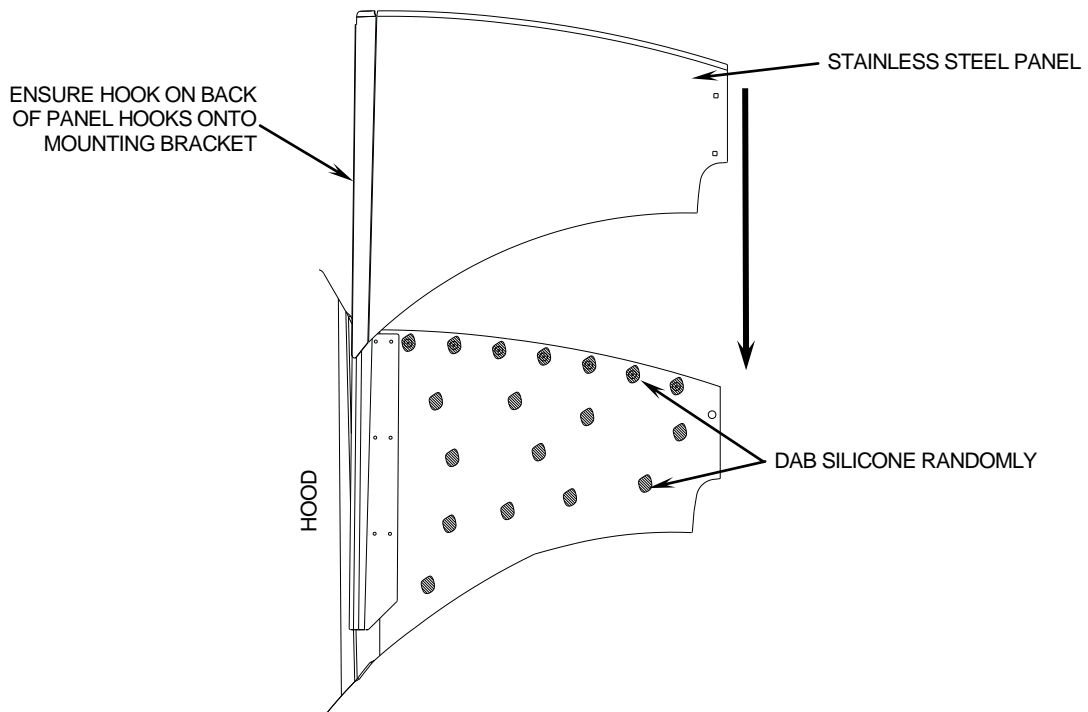

7. Close the hood and drill 2, 1/4" hole through bottom square holes into hood. Slide spacer washers between hood and panel. Install 1/4-20 carriage bolts through holes and secure using 1/4 flat washers and 1/4-20 lock nuts supplied.

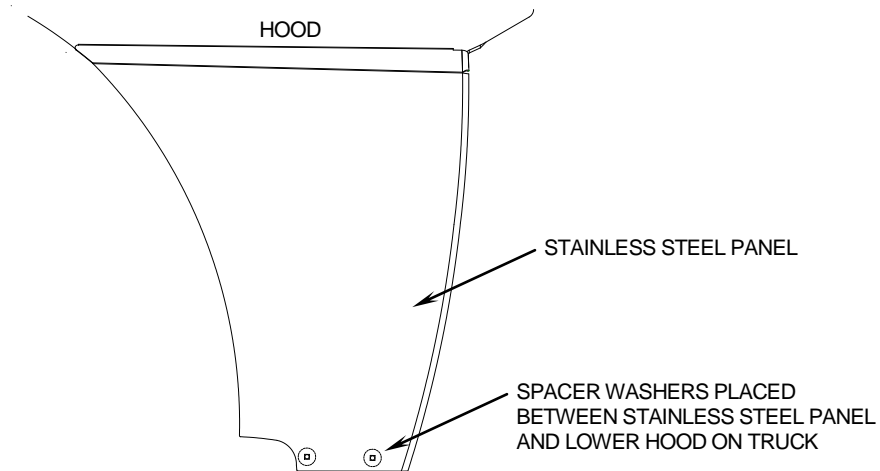

8. Carefully peel plastic from panel and clean with glass cleaner if necessary.