

## STAINLESS STEEL ACCESSORIES

### SLEEPER SKIRTS – W900L 2008+, without extender

#### INSTALLATION INSTRUCTIONS

1. Peel plastic coating away from edges of sleeper skirt and around the bolt holes.
2. Hold sleeper skirt in desired position flush with outside of sleeper. This will determine the placement of the brackets.
3. The brackets may either be screwed to sleeper floor panel or bolted to sides of cross members. If the desired installation is to attach the skirt to the sleeper floor, then it will be necessary to use both brackets supplied in the bracket kit. (Fig. 1) If installing skirt using only the cross rails under the sleeper, only one bracket is required. (Fig. 2)

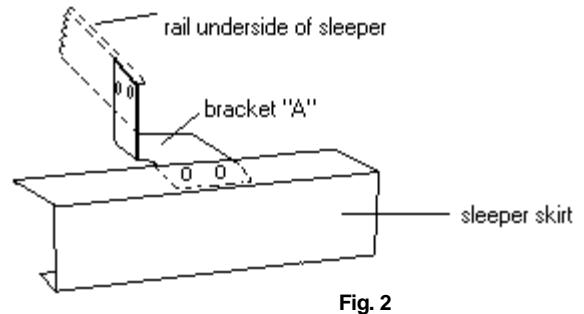
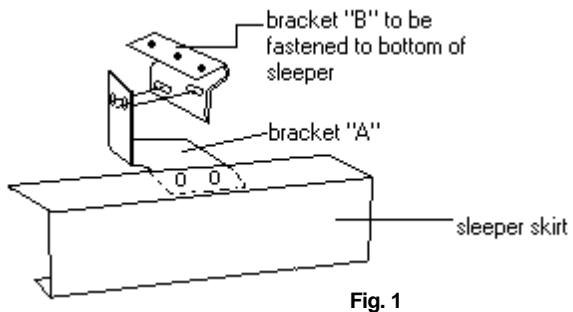

4. If you fasten the bracket to the sleeper floor, then drill 1/8" hole into floor and use self tapping screws supplied. When fastening the bracket to cross member drill 9/32" holes and use 1/4" bolts, washers, and nuts. Do not fully tighten.
5. Once the brackets are fastened, place the skirt back in position and fasten using the 1/4 hardware supplied.

6. Peel plastic from around bolt holes in the filler panel supplied in the bracket kit. This will be installed onto the cab skirt using the 10-32 hardware supplied. (Fig. 3)

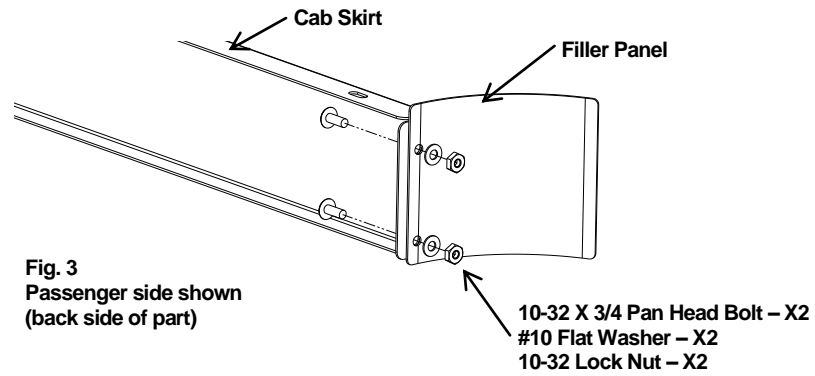

7. Ensure that all hardware is tightened and peel remaining plastic from all parts installed.
8. If necessary, clean sleeper skirt and filler panel with glass cleaner and a soft cloth.