

STAINLESS STEEL ACCESSORIES

10" SUNVISOR AEROCAB, REPLACEMENT FOR OEM SUNVISOR

INSTALLATION INSTRUCTIONS

1. DO NOT REMOVE entire plastic coating until the last step. Peel plastic from edge around all bolt holes and in areas shown below.

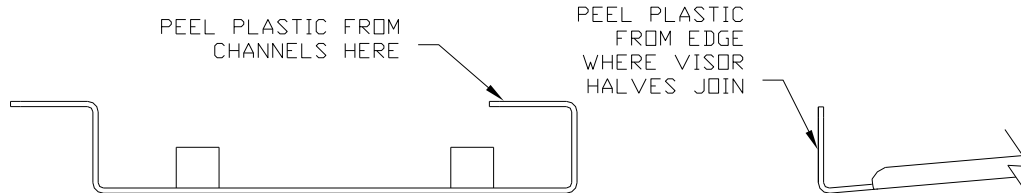

2. Remove factory sunvisor. Leave factory brackets fastened to cab.
3. Fasten visor halves together with (3) 1/4-20 hex bolts, (6) 1/4" flat washers, (3) 1/4" locknuts. Ensure flanges line up with each other and tighten fully. See below.

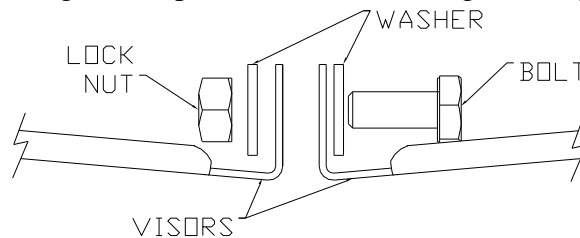

4. Attach channels to corresponding visor halves with (8) M6 x 20 pan head screws, (8) M6 locknuts and (16) 1/4" flat washers. Leave slightly loose to allow for adjustment. Take care to center the slots of the channel with the slots of the visor in horizontal direction. See diagram below.

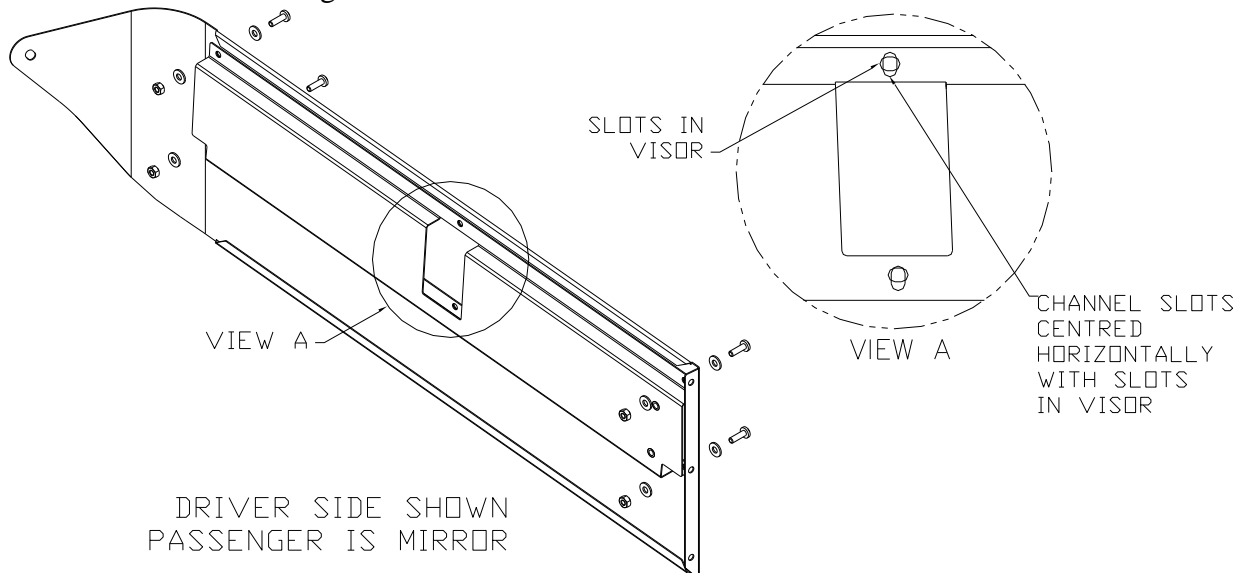

5. Fasten center bracket to channels using (4) 1/4-20 hex bolts and (4) 1/4" lock washers. Leave slightly loose to allow for adjustment. See below.

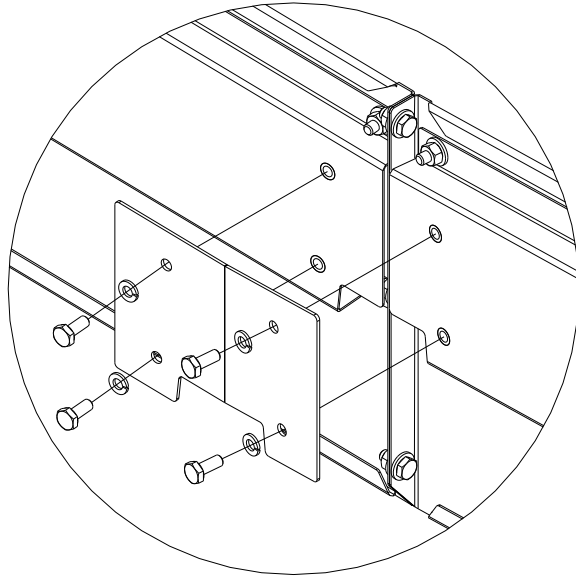

6. Attach entire assembly to factory brackets using (4) M6 x 20 pan head screws and (4) 1/4" flat washers. See below, arrows indicate direction of factory brackets.

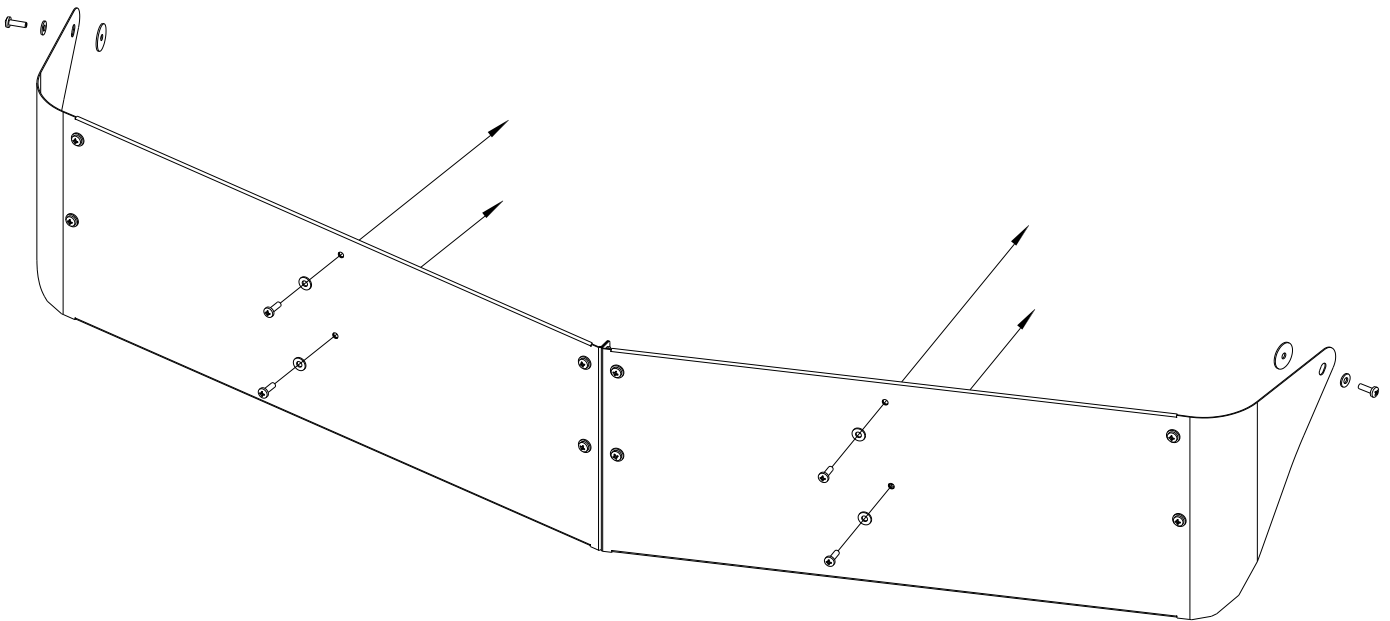

7. Fasten the ends of the visor using (2) M6 x 20 pan head screws, (2) 1/4" flat washers and (2) plastic washers. Leave slightly loose to allow for adjustment. See above.
8. Now the entire visor assembly is in place. Before final tightening of fasteners ensure the visor lines up properly, and appears symmetrical about the center of the truck.
9. Tighten fully the screws into preexisting factory brackets.
10. Tighten fully the screws attaching channels to the visor.
11. Tighten fully the screws attaching center bracket to channels
12. Tighten fully the screws into the ends of the cab.
13. Remove plastic coating from entire visor.