

STAINLESS STEEL ACCESSORIES

FUEL TANK SKIRT

INSTALLATION INSTRUCTIONS

1. Do not remove plastic coating until the last step, to prevent scratches.
2. Leave all bracket bolts semi-loose (for bracket movement) until the last step.
3. Assemble brackets as shown in diagram.

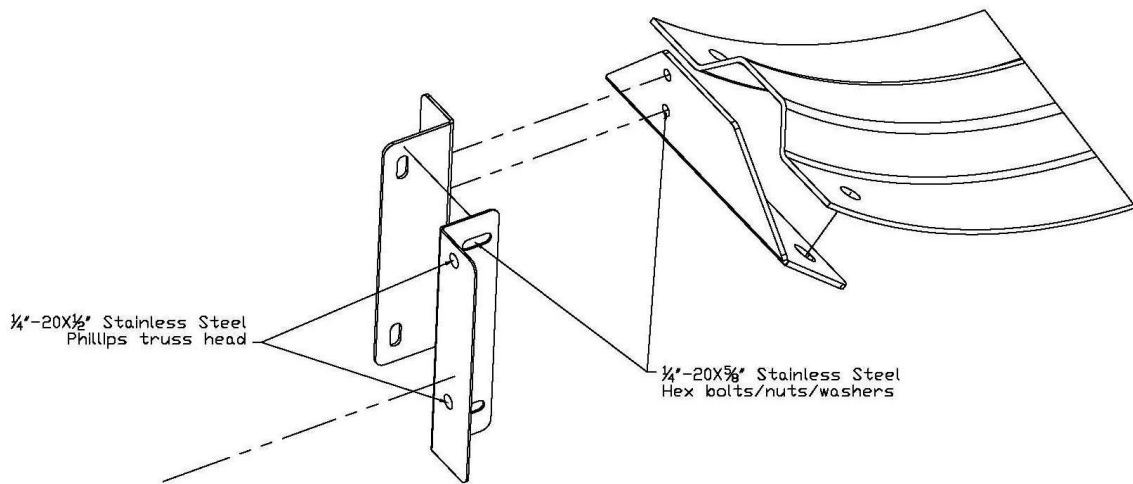

4. Leave the adjusting bracket only snug, to facilitate further adjustment.
5. Carefully line the tank skirt up with the tank in a suitable position. Drill through the skirt, and bracket in line with the fuel tank straps. Bolt the skirt and brackets together using 1/4" x 1/2" Phillips Truss hardware.
6. Once all the hardware is tightened in the desirable position, remove the remaining plastic coating.

