

STAINLESS STEEL ACCESSORIES

SUNVISOR, PROSTAR

INSTALLATION INSTRUCTIONS

1. Remove the existing sun visor and wiring harness from the truck. Keep existing mounting bolts, as they will be required for re-assembly of the new visor.
2. Detach the lights (or use supplied X2 lights) and install on the new sun visor. Connect the wiring harness to all lights, but do not screw in the centre and outside lights as these light holes will be required for mounting the visor to the truck.
3. Fully fasten the centre bracket to the visor panels as shown below. First fasten the 10-32 hardware then the 1/4-20 hardware. Please note that the 10-32 locknut and washer are only required for one hole. The other (4) holes have threaded inserts and require only the screw for fastening.

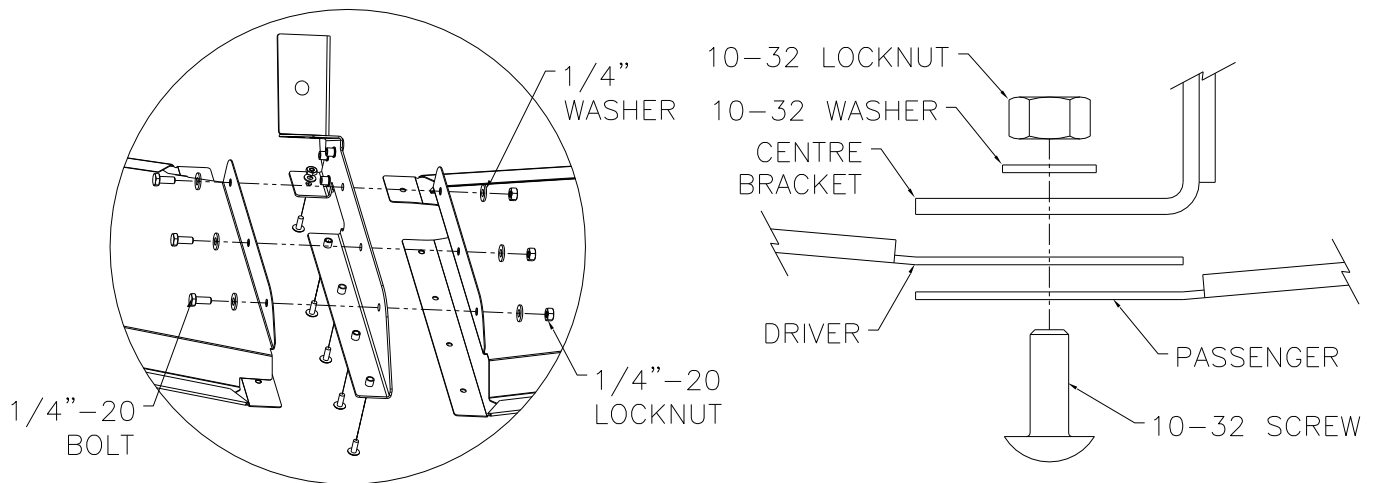

4. Loosely fasten the outside brackets to the visor panels as shown below. Tighten only 3/4" tight in order to allow for future adjustment as required. First fasten the 10-32 hardware then the 1/4-20 hardware.

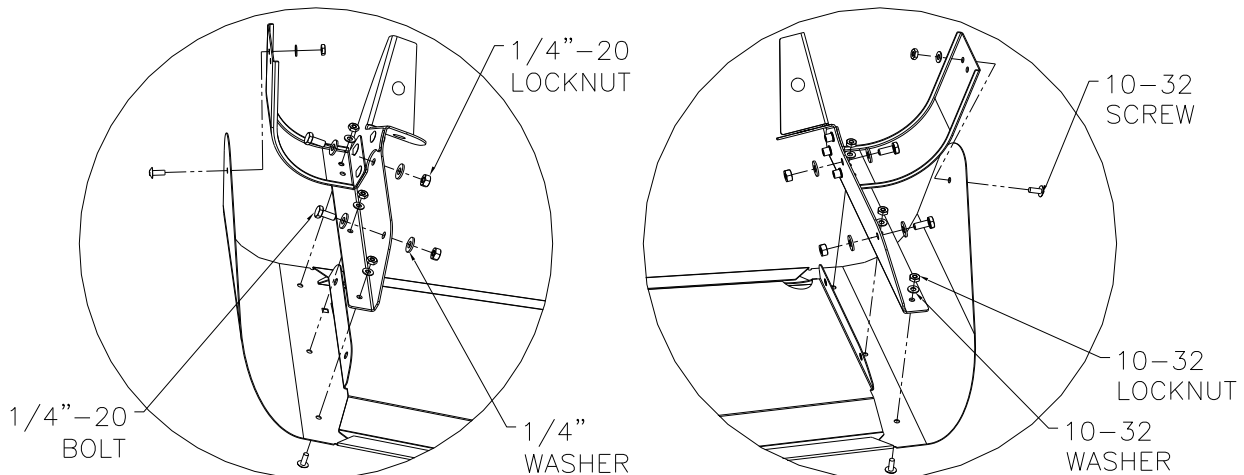

STAINLESS STEEL ACCESSORIES

5. Using the previously removed factory bolts screw the visor assembly into the truck through the center bracket.
6. Align the visor assembly so that the outside bracket holes line up with the holes in the truck.
7. Fasten the outside brackets to the truck as shown below.

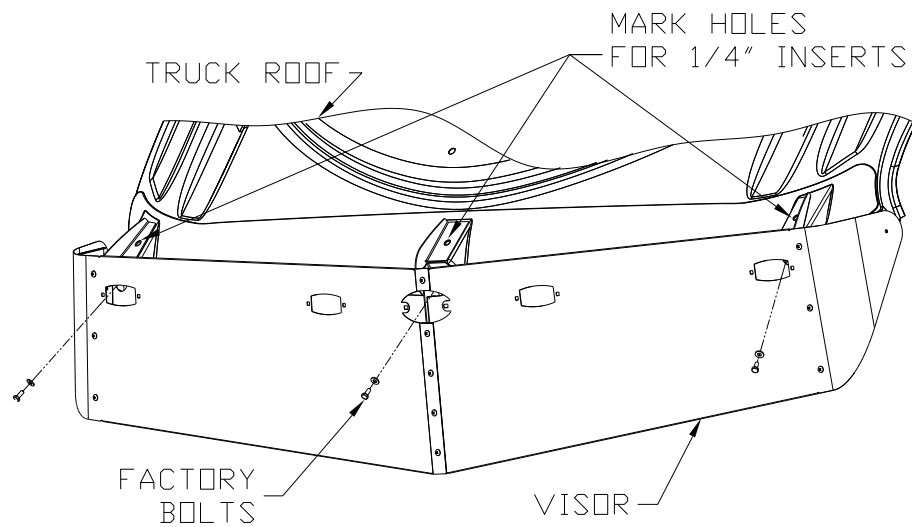

8. At this time it is very important to ensure the proper alignment of the visor and that the top of all three brackets sit flush on top of the mounting pads on the truck.
9. Mark the holes on to the truck through the holes in the top mounting flange of the brackets.
10. Remove visor assembly.
11. Drill into these marked holes and install inserts as per "Nut-Insert Tool Instructions"
12. Apply silicone **generously** in and around all holes in cab. This will create a proper seal between the mounting surface of the brackets and the cab, thus preventing water leakage.
13. Reinstall visor as per steps 5-7.
14. Fasten the tops of the brackets into the previously installed 1/4" inserts as shown below.

STAINLESS STEEL ACCESSORIES

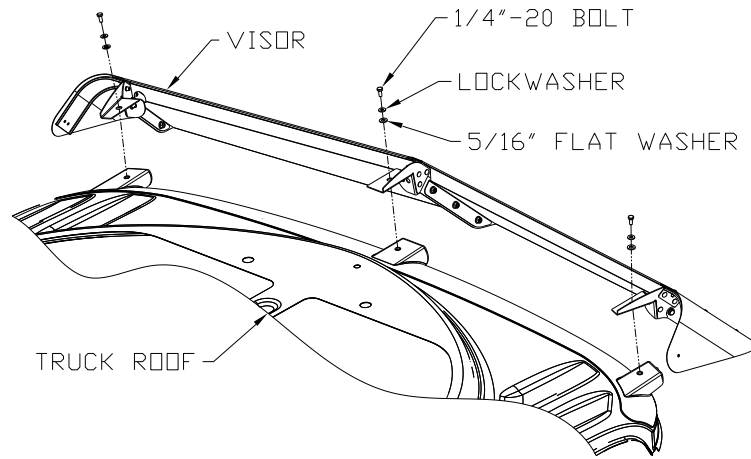

15. Fully fasten the outside brackets that were previously $\frac{3}{4}$ " tightened in step 4.
16. Remove the plastic and clean with glass cleaner if required.