

## Universal Stainless Steel Accessories

### UNIVERSAL HOOD WING

#### INSTALLATION INSTRUCTIONS

1. Pull back plastic coating from the bottom of wing around brackets.
2. Remove Plastic coating around all bolt holes.
3. A choice of mounting bracket is required, Peterbilt trucks will need the shorter bracket, while the Kenworth trucks use the higher bracket.

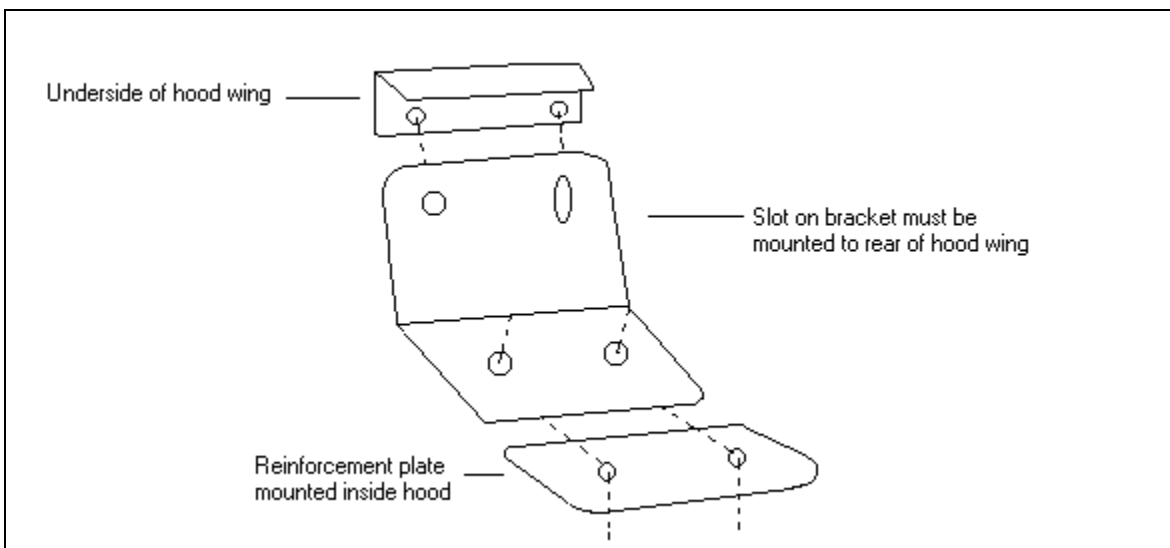

4. Install the chosen bracket onto the fixed hood wing bracket, while Kenworth trucks use the higher bracket.
5. Once the proper brackets are installed, set the hood wing into desired position. Now mark spots through the bracket holes on paint.
6. Before drilling holes through hood. Check that there are no obstacles inside.
7. Once the holes are drilled, place hood wing in position again, insert bolts through holes into hood.
8. Use the supplied reinforcement plates on inside of hood, install washers and nuts, and tighten.
9. Now set the hood wing at desired angle and tighten bracket hardware. Remove remainder of protective coating.